

PHC

TIMING DRIVE

- TENSIONER BEARING
- IDLER BEARING
- TIMING BELT
- WATER PUMP

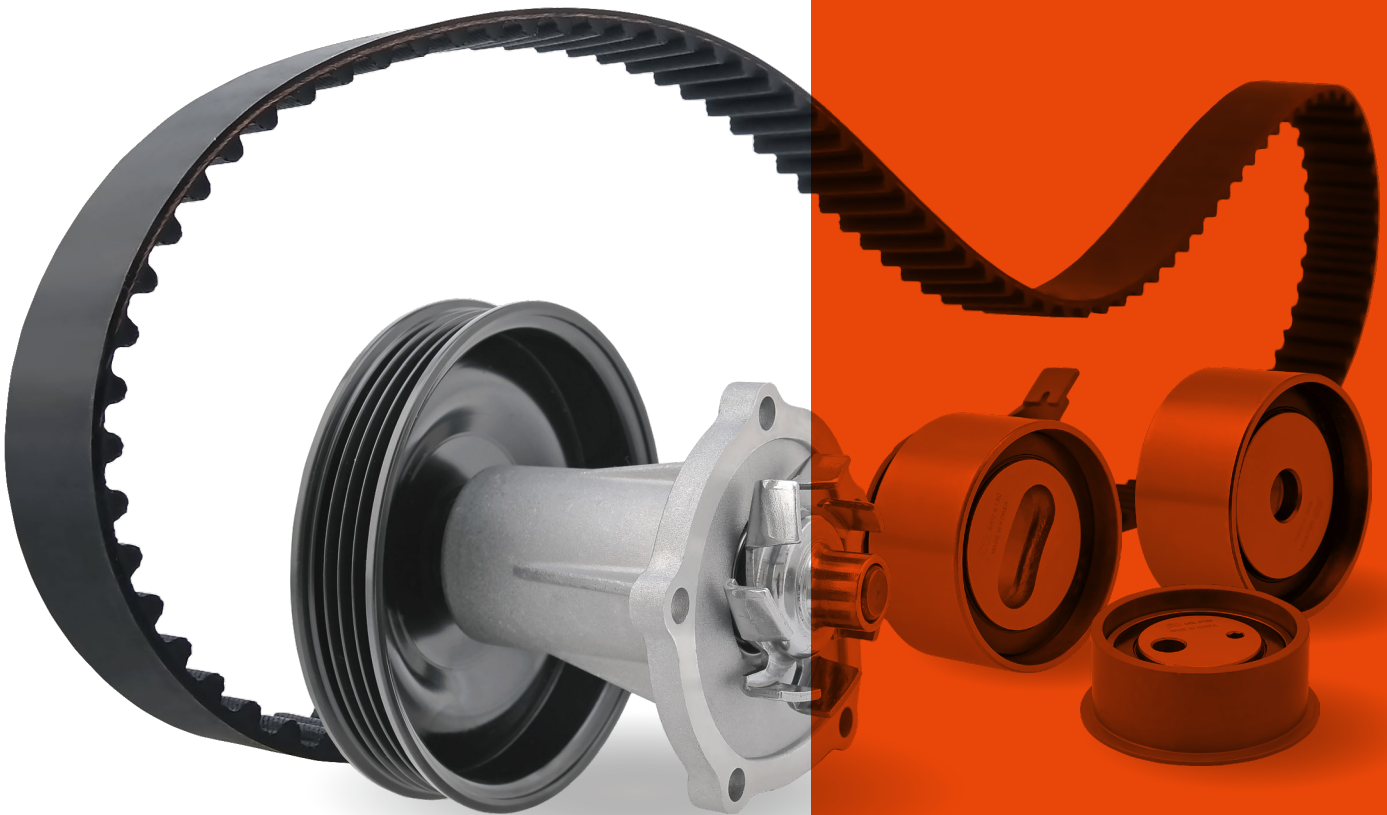

GET ALL
COMPONENTS AT ONCE



TIMING DRIVE COMPONENTS

PHC, Korea No.1 Aftermarket Auto Part Brand
With over 50 years of experience in the automotive parts industry, PHC supplies the highest quality auto parts to the global aftermarket with wide range at reasonable price.

PHC has succeeded in supplying high-performance timing drive components such as Tensioner bearing, Idler bearing, Timing belt and water pump with advanced technology and is continuing its reputation as a global aftermarket auto parts distributor by supplying cutting-edge products.

PHC timing drive solution helps you making replacement with simple and efficient. The individual components are perfectly matched to ensure optimum functionality of the vehicle after repair.

OE QUALITY WIDE RANGE



GET ALL COMPONENTS AT ONE STOP WITH PHC

- TENSIONER BEARING
- IDLER BEARING
- TIMING BELT
- WATER PUMP

FEATURES OF TENSIONER & IDLER BEARING



Benefits

- OE quality.
- IATF16949 / ISO14001.
- Proper material selection for high temperature use.
- Rigorous quality control system.
- Strict production management.

Vehicle Coverage

ALFA ROMEO, FIAT, LANCIA, ASIA, AUDI, SEAT, SKODA, VW, VOLVO, BMW, CHEVROLET, OPEL, GM DAEWOO, VAUXHALL, CHRYSLER, CITROEN, PEUGEOT, FORD, RANGE ROVER, SUZUKI, DAIHATSU, TOYOTA, DODGE, BENZ, MAZDA, HYUNDAI, KIA, MITSUBISHI, ISUZU, LADA, NISSAN, RENAULT

FEATURES OF TENSIONER & IDLER BEARING

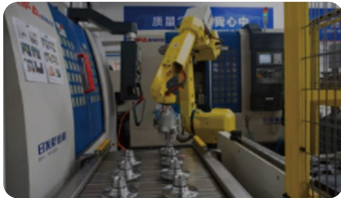
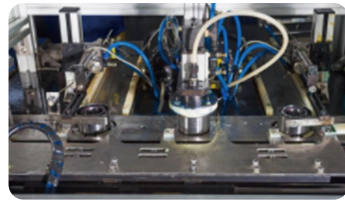

High end technology and automated production lines

PHC Tensioner & Idler bearings are manufactured by over 400 leading processing equipment with digital control technology to facilitate full process control, a solid hardware guarantee for us to offer products that truly satisfy our customers.

Full spectrum quality inspection facilities

All kinds of high precision testing instruments are worked for the production field directly. It will control the whole production process in time and promise the size, shape, performance consistency and stability.

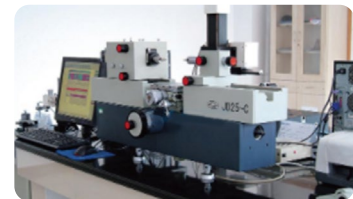
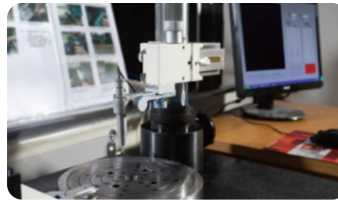

FEATURES OF TIMING BELT



Benefits

- OE Products.
- IATF16949 / ISO9001.
- Quieter running.
- No lubrication needed.
- Non-slip engagement.
- Economical operation.
- Excellent mechanical efficiency.

Vehicle Coverage

ALFA ROMEO, AUDI, CHERY, CHEVROLET, GM DAEWOO, DAIHATSU, FIAT, FORD, GREAT WALL, HONDA, HYUNDAI, INFINITI, ISUZU, KIA, LEXUS, MAZDA, MITSUBISHI, NISSAN, OPEL, RENAULT, SEAT, SUBARU, SUZUKI, TOYOTA, VAUXHALL, VOLKSWAGEN, SAAB

FEATURES OF TIMING BELT

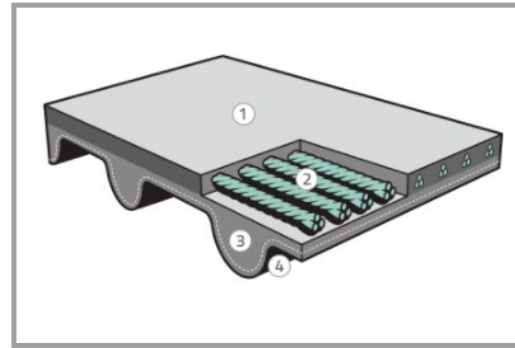

Construction	Functions	Materials
①Rear fabric	Protection of tension member	CR, HNBR
②Tension member	Primary material for transferring power	Glass Fiber
③Teeth rubber	Tension member protection and belt shape maintaining	CR, HNBR
④Bottom fabric	Belt and teeth maintaining	Nylon

FEATURES OF WATER PUMP

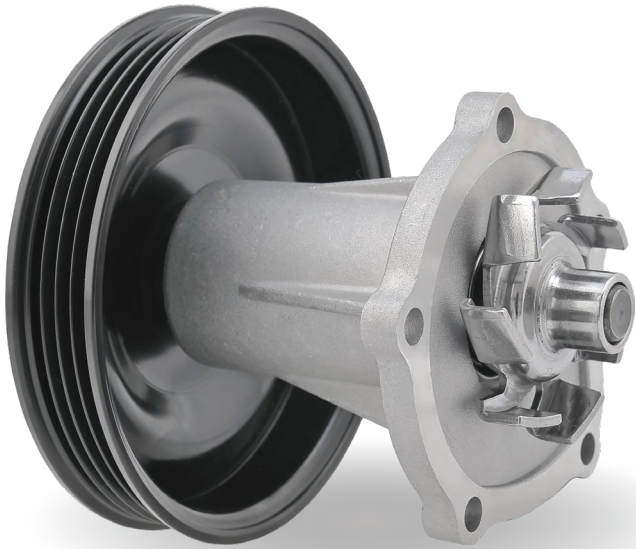

Benefits

- OE quality.
- IATF16949.
- Optimal cooling without excessing Load to the engine.
- The highest quality materials are used.
- Strong body design.
- High resistance to corrosion.

Vehicle Coverage

AUDI, BMW, BUICK, CHEVROLET, GM DAEWOO, CITROEN, DACIA, DAIHATSU, FORD, HONDA, HYUNDAI, ISUZU, KIA, MAZDA, MITSUBISHI, NISSAN, OPEL, PEUGEOT, PROTON, RENAULT, SSANGYONG, SUBARU, SUZUKI, TOYOTA, VOLKSWAGEN

FEATURES OF WATER PUMP



High end technology and Automated production lines

PHC water pumps are produced by stable and robust production systems such as process control systems and automated production lines with high end quality equipment. Specially, an automation system and all processes like quality control and defects are controlled by systematically management for manufacturing high quality products.

Top-notch quality inspection facilities

In this way, PHC provides the best products through a thorough quality inspection and numerous tests. PHC thoroughly monitors all processes and does the best to provide excellent quality.

TIMING BELT KIT



- TENSIONER BEARING
- IDLER BEARING
- TIMING BELT

(Without Water pump)

PHC TIMING DRIVE SOLUTION

PHC has put together intelligent KITS for changing timing belts to make replacement with simple and efficient. The individual components are perfectly matched to ensure optimum functionality of the vehicle after repair.

PACKAGING QUALITY ASSURANCE SERVICE



Packaging

Packaging Protective & Solid Applicable to all sizes of Products

PHC products are packed in packaging box and solid cardboard box. These layers of protection prevent any damages during transportation. Also, the improved packaging is suitable for covering all sizes of products.

Quality Assurance

Highly ensured product reliability and quality

With an extensive and stringent quality control system, PHC products are free from any types of defects in materials and workmanship. Also, PHC is striving for customer satisfaction and ready for customer requests.

Customer Service

Delivery

PHC is always punctual on delivery dates and accurate in delivering the right items. Controlling over 40 product lines proves a highly organized logistics system. Find more items via our web page, 'www.koreavaleo.com'.

Quotation & Find the right parts

We are always ready for a quick response. Please visit the PHC web page or web catalog for more information.

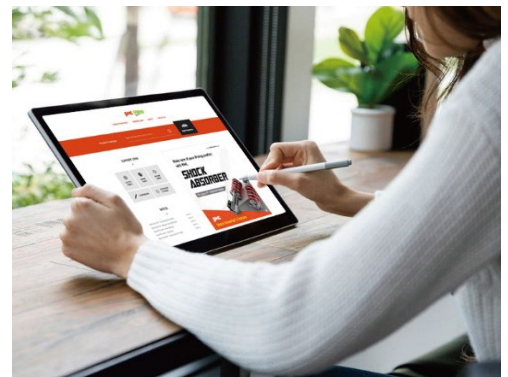



Contact us

Tel. +82-2-734-3711 / +82-54-930-0543

E-mail. marketing-vphi@vph.com

Website

Web page: www.koreavaleo.com

Web catalog: www.phcvaleo-webcat.com



Find the right spare parts on web-catalog

Valeo Pyeong Hwa International Co.,Ltd.